



Principal

Design Bodil Kjær

Year 1961

Bodil Kjær

She has been featured in The New York Times and Wall Street Journal Magazine. She designed a desk for MIT which was dubbed 'The most beautiful desk in the world' and eventually immortalized in three early James Bond movies. Danish architect, designer and professor Bodil Kjær (born 1932) is the female trailblazer of Danish midcentury design, who although tutored by modernist master Finn Juhl, in her own words "... never had much interest in following in the footsteps of the Danish rat pack". Kjær looked to America, inspired by Charles and Ray Eames, and indeed many of her most notable designs stems from her time in the U.S., where she briefly worked at Paul McCobb, before moving to Boston to further her career in corporate interior architecture. Kjær's reignited prominence as a designer in later years is well deserved. Pared back, elegant and decidedly modern, her iconic pieces slip effortlessly into contemporary life 60 years on.



One of the last living mid-century Scandinavian design pioneers and a female pioneer in the field of architecture in her time, Bodil Kjær, conceived her Principal series in 1961 as part of an architectural exploration of interior solutions for modern living, called Elements of Architecture. Comprising a dining table and an upholstered dining chair, the Principal series epitomises Kjær's forward-thinking cosmopolitan outlook and modernistic design language that slips fluidly into contemporary interior.

The solid wood dining table boasts a clarified form, repeating a simple angle throughout table legs and ends of the table top, while the dining chair with its circular seat and gently rounded backrest, beautifully upholstered, adds a softness to the clear, unfussed geometry, an invitation to linger.

INDEX

Principal chair	p. 3
Principal dining table	p. 4
Frames and upholstery	p. 5



Principal chair

PRODUCT DATA

Design	Bodil Kjaer. 1961
Product type	Chair
Environment	Indoor
Weight (net)	4,6 kg / 10.1 lbs
Materials	Frame in solid oak or walnut with clear lacquer, seat and backrest upholstered with leather or textile

VARIANTS

Frames	Natural oak White stained oak Smoke stained oak Walnut
--------	---

DELIVERY

Lead time	6 to 8 weeks
Packing	Assembled

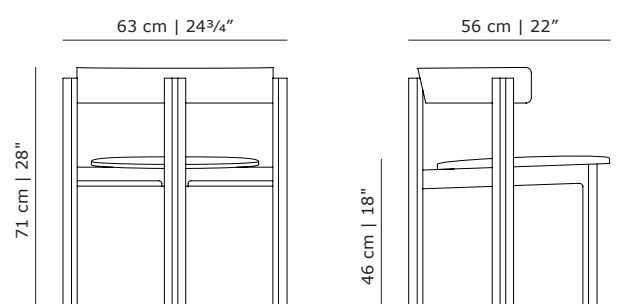



Principal dining table

PRODUCT DATA

Design	Bodil Kjør. 1961
Product type	Dining table
Environment	Indoor
Weight (net)	40 kg / 88.2 lbs
Materials	Frame in solid oak or walnut with clear lacquer, table top in oak or walnut veneer with clear lacquer

VARIANTS

201714	Principal dining table, natural oak
201739	Principal dining table, white stained oak
201740	Principal dining table, smoke stained oak
201705	Principal dining table, walnut

DELIVERY

Lead time	6 to 8 weeks
Packing	Flat packed

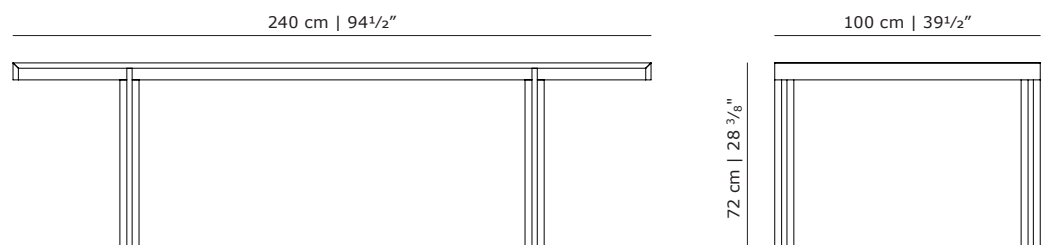



Principal

Frames and upholstery

Chair

Dining table



Solid oak natural



Solid oak white stained



Solid oak smoke stained



Solid walnut



Solid oak, oak veneer, natural



Solid oak, oak veneer white stained



Solid oak, oak veneer, smoke stained



Solid walnut, walnut veneer

Upholstery - Sørensen Leather



Elegance walnut



Elegance mocca

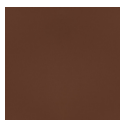

Savanne cognac



Savanne dark brown



Flux dark green



Flux light brown



Ultra brandy



Ultra chocolate

Upholstery - Kvadrat



Remix 3 123

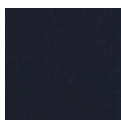

Remix 3 773

Note: See standard combinations and article codes in our price list.



Karakter

Gammel Lundtoftevej 1C
2800 Kongens Lyngby
Denmark

+45 3841 4131

www.karakter-copenhagen.com

info@karakter-copenhagen.com

[@karaktercopenhagen](https://www.instagram.com/karaktercopenhagen)

[#karaktercopenhagen](https://www.facebook.com/karaktercopenhagen)